



MYOSCAN-PRO SENSOR
T9401M-60 & T9401M-50

Measure More
Sense Better

Technical Note Series

MYOSCAN-PRO SENSOR (T9401M-60 & T9401M-50)



IMPORTANT OPERATION INFORMATION



- Type BF Equipment
- Internally powered equipment
- Continuous operation



WARNING

- If the sensor is interfaced to non-Thought Technology devices without the use of a TT Sensor Isolator SE9405AM, an elevated risk of electrical shock may be present. In particular, if a client-connected sensor is connected to any line powered device(s) or equipment(s), it will be the responsibility of the qualified user to ensure the electrical safety in the setup.
- Explosion Hazard; Do not use in the presence of a flammable anesthetic mixture with air, or with Oxygen or Nitrous Oxide.
- Not to be immersed in water.



CAUTION

- Connection of customer supplied circuits to Thought Technology sensor products has the potential to damage the sensor. Such damage is not covered by warranty.



ATTENTION

- For research only. Not for use in diagnostic procedures.
- To prevent voiding warranty by breaking connector pins, carefully align white guiding dot on sensor plug with slot on sensor input.

MAINTENANCE AND CALIBRATION

- Wipe with a clean cloth
- Factory testing and calibration ensure equipment accuracy and frequency response.
- No preventative inspections required;

STORAGE

- Temperature -23C – +60C
- Humidity (non-condensing) 10% – 90%
- Atmospheric pressure 700 – 1060 KPa

TRANSPORTATION

- Temperature -23C – +60C
- Humidity (non-condensing) 10% – 90%
- Atmospheric pressure 700 – 1060 KPa

PRODUCT OVERVIEW

The MyoScan-Pro line of sensors is differential amplifier of surface electromyography (sEMG). This means that whatever electrical activity is common to both sites is rejected, and what differs is amplified.

Surface EMG is a non-invasive measure of underlying muscle activity by detecting and amplifying tiny electrical impulses generated by muscle fibers when they contract.

The sensor detects and averages a complex addition of impulses from many muscle fibers within the recording area of the sensor, contracting at different moments and at different rates. The number of muscle fibers that are recruited, and the rate of firing (contraction) of each fiber, during any given contraction depends on the force required to perform the movement. Because of this, the intensity (amplitude) of the resulting electrical signal, under certain conditions, is proportional to the strength of the contraction.

For more information on SEMG and its applications, the following free books are available for download:

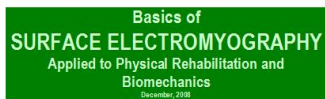

*Basics of Surface Electromyography
Applied to Psychophysiology*

www.thoughttechnology.com/semg.htm



Thought Technology Ltd.
2700 Steeles Avenue East, Suite 202
Markham, ON L3R 9V7
Tel: 905.477.1111
Fax: 905.477.1112
Email: sales@thoughttechnology.com
Website: www.thoughttechnology.com



**Basics of
SURFACE ELECTROMYOGRAPHY**
Applied to Psychophysiology



*The Basics of Surface Electromyography
Applied to Physical Rehabilitation and Biomechanics*

www.thoughttechnology.com/semgbasic.htm

Thought Technology Ltd.
2700 Steeles Avenue East, Suite 202
Markham, ON L3R 9V7
Tel: 905.477.1111
Fax: 905.477.1112
Email: sales@thoughttechnology.com
Website: www.thoughttechnology.com



OPERATING PRINCIPLE

The MyoScan-Pro sensor senses and amplifies EMG signal and then performs an analog root mean square (RMS) conversion on the signal. It results in a relatively slowly changing signal which follows the amplitude of the input EMG signal, and which can be sampled at a lower rate than what is required for raw EMG.

Before the RMS conversion, the SEMG signal is notched to remove power line frequencies which are present in many environments. MyoScan-Pro T9401M-60/SA9401M-60 notches at 60Hz and MyoScan-Pro T9401M-50/SA9401M-50 at 50Hz.

The MyoScan-Pro sensor's frequency response is from 20 to 500 Hz. It responds to SEMG signals up to 1600 micro-volts (μV) RMS. On the back of the sensor, there is a small switch with three positions: 400N, 1600W and 400W:

- In the **400W** (wide bandwidth) position, the sensor will be sensitive to the full 20-500Hz bandwidth. SEMG signals recorded from upper body muscles may contain EKG interference from heart muscle. This is usually seen as a spike occurring at every heartbeat.
- This noise can be filtered out by moving the switch to the **400N** (narrow bandwidth) position. In this position, the sensor will only be sensitive to frequencies between 100 and 200 Hz.

While the **400 (W and N)** settings provide good resolution for most of the body's muscles, the third position, **1600W** is for monitoring larger muscle groups like thigh muscles, where the signal level may go above $400\mu\text{V}$ RMS. In this setting, the sensor responds up to a level of $1600\mu\text{V}$ RMS.

Zeroing

Since the MyoScan-Pro uses internal electronic circuitry to perform RMS conversion, small offsets are sometimes observed in the sensor reading. For that reason, it will occasionally be necessary to zero your MyoScan-Pro sensors. Zeroing is done by connecting the zeroing plug to the sensor box (plug it where the extender cable connects).



With the zeroing plug on the sensor, the reading should be zero. If your software displays a different value, usually plus or minus a few microvolts, then you should be able to correct this offset, from within the software, by using a zeroing function. Keep in mind that each sensor may have different offset values, and that the offset may change, particularly with temperature. **Remember to remove the zeroing plug after adjusting the MyoScan-Pro sensor's offset.**

SKIN PREPARATION

Although it is possible to use the MyoScan-Pro sensor with dry electrodes and no skin preparation, doing so increases the chance that artifacts will distort the signal. As a general rule, skin preparation enhances signal quality, reduces artifacts and minimizes the need for post-recording artifact rejection.



At a minimum, make sure that before applying the EMG electrodes the skin surface is clean and dry by rubbing it with an alcohol pad. However, to significantly reduce artifacts, we recommend abrading the skin with an abrasive cream, such as NuPrep (10-30), to remove dead skin. If necessary, shave excess body hair.

SENSOR PLACEMENT

For best results, silver-silver chloride electrodes are recommended for electrical contact between skin and sensor. The single-use Triode electrode (T3402M) should be your first choice. It can be snapped directly on the sensor head, which makes it very easy to use and to position. The signal is then amplified right on the muscle site, which dramatically increases the SNR (Signal-to-Noise Ratio) and therefore limits pollution of the SEMG signal by surrounding electromagnetic fields and movement artifacts generated by wires being pulled.



The distance between the electrodes is also optimal (standard 2cm) for avoiding or limiting muscle crosstalk.



Conductive gel is recommended for optimal electrode-skin contact. The gel can be applied to the center (on the grey area only) before applying to the skin. Make sure the electrodes are placed firmly on the skin.



The UniGel electrodes (T3425) provide total freedom in term of placement. Their small size also allows placement on very tiny muscles (such as SCM). They are not attached together, which prevents them from moving on the skin when positioned on muscles with great deformation while contracting. These electrodes are pre-gelled and so do not require the addition of conductive gel, which reduces the time of preparation for this type of electrode. An EMG extender cable (T8720M) must be connected between the electrodes and the sensor.

TECHNICAL SPECIFICATIONS

Size (approx.)	37mm x 37mm x 15mm (1.45" x 1.45" x 0.60")
Weight with Cable (approx.)	25g (1 oz)
Input Impedance	1,000,000M Ω in parallel with 10 pF
Signal Input Range	0 – 400 μ V _{RMS} , 0 – 1600 μ V _{RMS}
Sensitivity	< 0.1 μ V _{RMS}
CMRR at 60 Hz (US), 50 Hz (approx.)	-180dB
CMRR over 20-500 Hz (approx.)	-130dB
Channel Bandwidth (Narrow)	100Hz (+10Hz/-20Hz) – 200Hz (+30Hz/-20Hz)
Channel Bandwidth (Wide)	20Hz (\pm 10Hz) – 500Hz (\pm 50Hz)
Signal Output Range	2.000V – 3.600V
Supply Voltage	7.26V \pm 0.05V
Current Consumption	2.5mA – 3.5mA
Accuracy	\pm 5% and \pm 0.3 μ V _{RMS}

ELECTRICAL COMPATIBILITY

The MyoScan-Pro sensor is designed to coexist with other Thought Technology bio potential sensors such as T9306 (or T9307) EKG sensor, T9305M EEG sensor, T7680 EEG-Z3 sensor, or SA9309M Skin Conductance sensor.

To ensure correct MyoScan-Pro sensor operation, if sensors from another manufacturer are in the same electrical circuit and connected to the same subject, their electrodes must function at a voltage within the specified operating bias range, 1.0 to 3.0 volts above sensor ground. To check whether another sensor is interfering with the MyoScan-Pro sensor operation, connect and disconnect the other sensor from the subject, and note whether this causes a change in the MyoScan-Pro sensor signal level, or whether connection of the other sensor appears to cause any signal artifacts in the EMG signal.

INTERFACING WITH 3RD PARTY DATA ACQUISITION SYSTEM

Recommended Connectivity for Electrical Safety

To ensure electrical safety in the user setup, Thought Technology recommends the use of TT Sensor Isolator SE9405AM when interfacing client connected sensor(s) to line powered equipment(s) or devices.



The TT Sensor Isolator SE9405AM is an interface device providing medical grade electrical isolation between the client connected sensors and the acquisition system. It provides the equivalent of Two Means of Client Protection under IEC 60601-1, and supplies battery power to the sensors. Using this device ensures Thought Technology sensors are safely interfaced to the analog inputs of line-powered systems such as computers with DAQ cards.

Note that this device isolates only between sensors and the DAQ interface, not between different sensor channels.

The TT Sensor Isolator can interface up to 4 sensors to a DAQ card. TT Sensor Isolator can be connected to the DAQ card in two ways:

- via two stereo jacks, or
- via a DB-15 connector; a BNC interface cable (SA9409BNC) or a pigtail cable (SA9409PGT) can be provided with the unit.

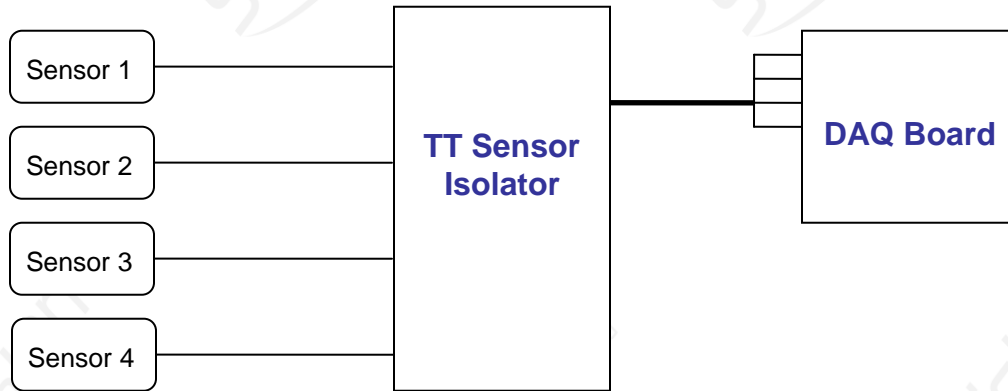

For more detailed information on the Sensor Isolator 4 ∞ , consult the Thought Technology Science Division website or contact the sales department or an authorized distributor.

Direct Connectivity for Electrically Isolated Systems

The following notes are provided for qualified users to directly interface Thought Technology sensors with external systems.

WARNING: If the sensor is interfaced to non-Thought Technology devices without the use of a TT Sensor Isolator SE9405AM, an elevated risk of electrical shock may be present. In particular, if a client-connected sensor is connected to any line powered device(s) or equipment(s), it will be the responsibility of the qualified user to ensure the electrical safety in the setup and to ensure that the device or equipment provides sufficient isolation.

To interface with a sensor, a single sensor cable may be cut in half. Both sides can then be used to make custom interfacing cables by stripping the outer insulation of each required conductor. The sensor cable contains 4 color coded conductors. The table below shows the color coding and pin connector assignment.

Pin	Color code	Function	Note
1	metal (shield)	ground	Signal and power ground, connection required.
2	yellow	auxiliary (sensor ID)	No connection required.
3	green	signal	Sensor output signal
4	red	sensor power	Supply voltage, +7.26V referenced to ground. Note: sensor performance may be sensitive to supply voltage.

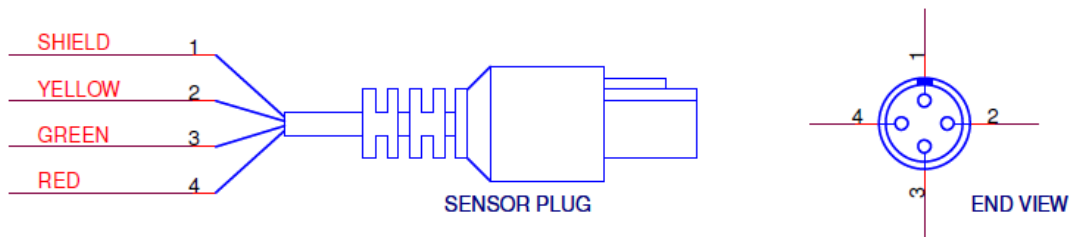

Notes:

1. The nominal supply voltage for this sensor is 7.26V. The sensor can safely be used with a supply voltage of up to 9V.

Recommended Specifications for DAQ Hardware

- Recommended resolution of 0.15mV (16-bit ADC over 10V span) or better
- Minimum input range:
 - If connected via SE9405AM Sensor Isolator, choose 0-5V (unipolar) or ±5V (bipolar)
 - If directly connected to DAQ, choose ±5V (bipolar).

Simplified Transfer Function

Switch setting	Output voltage from input	Input voltage from output
400W, 400N	$V_{out} = 2.0 + 4000V_{in} (RMS)$	$V_{in} (RMS) = \frac{V_{out} - 2.0}{4000}$
1600W	$V_{out} = 2.0 + 1000V_{in} (RMS)$	$V_{in} (RMS) = \frac{V_{out} - 2.0}{1000}$

V_{out} : Output voltage (input to DAQ)

V_{in} : Input voltage (RMS EMG signal)

Notes:

- The high pass effect of the sensor's AC is not shown in the Transfer Function. The function is accurate for frequency components within the specified bandwidth, and should adequately represent the scaling of an EMG signal.

SPECIFICATIONS SUMMARIES OF SUPPORTED ACCESSORIES/ HARDWARE

The table below lists Thought Technology accessories for the MyoScan-Pro.

Accessory	Product Number
-----------	----------------



T8720M EXTENDER CABLE 21in, 53cm



T3402M – Triode electrode (single use):

The Triode should be your first choice. It can be snapped directly onto the sensor head, which makes it very easy to use and quick to position. The signal is then amplified right over the muscle site, which dramatically increases the SNR (Signal-to-Noise Ratio) and limits contamination of the SEMG signal from surrounding electromagnetic fields and from movement artifacts generated by wires being pulled.



T3425 – UniGel electrodes (single use):

UniGel electrodes provide complete placement freedom. Their small size allows placement on very tiny muscles (such as SCM). Since they are not attached together, they may adhere better at sites where the skin undergoes great deformation while underlying muscles contract. UniGel electrodes are also pre-gelled and do not require the addition of conductive gel, which can reduce preparation time. An EMG Extender Cable (T8720M) connects these electrodes to the sensor.



SA2306 - EMG Headband (single client re-use):

The EMG Headband enables easy EMG measurement from the forehead (frontalis), which is a common EMG placement for stress/relaxation biofeedback. The headband accommodates 3 snap electrodes (Ag-AgCl) that work with the EMG Extender Cable (T8720M).